

LEGEND:

- LOCUS PROPERTY LINE	
- TREE & TREE TO BE REMOVED	
- DRAIN MANHOLE (DMH)	
- SEWER MANHOLE (SMH)	
- CATCH BASIN (CB)	
- GAS VALVE	
- WATER VALVE	
- WATER SERVICE	
- HYDRANT	
- UTILITY POLE	
- NOW OR FORMERLY	N/F
- SEWER PIPE	
- DRAIN PIPE	
- WATER MAIN	
- GAS SERVICE	
- OVERHEAD WIRES	
- UNDERGROUND WIRES	
- 1' CONTOUR INTERVAL	-272-
- 5' CONTOUR INTERVAL	-280-

EXISTING:

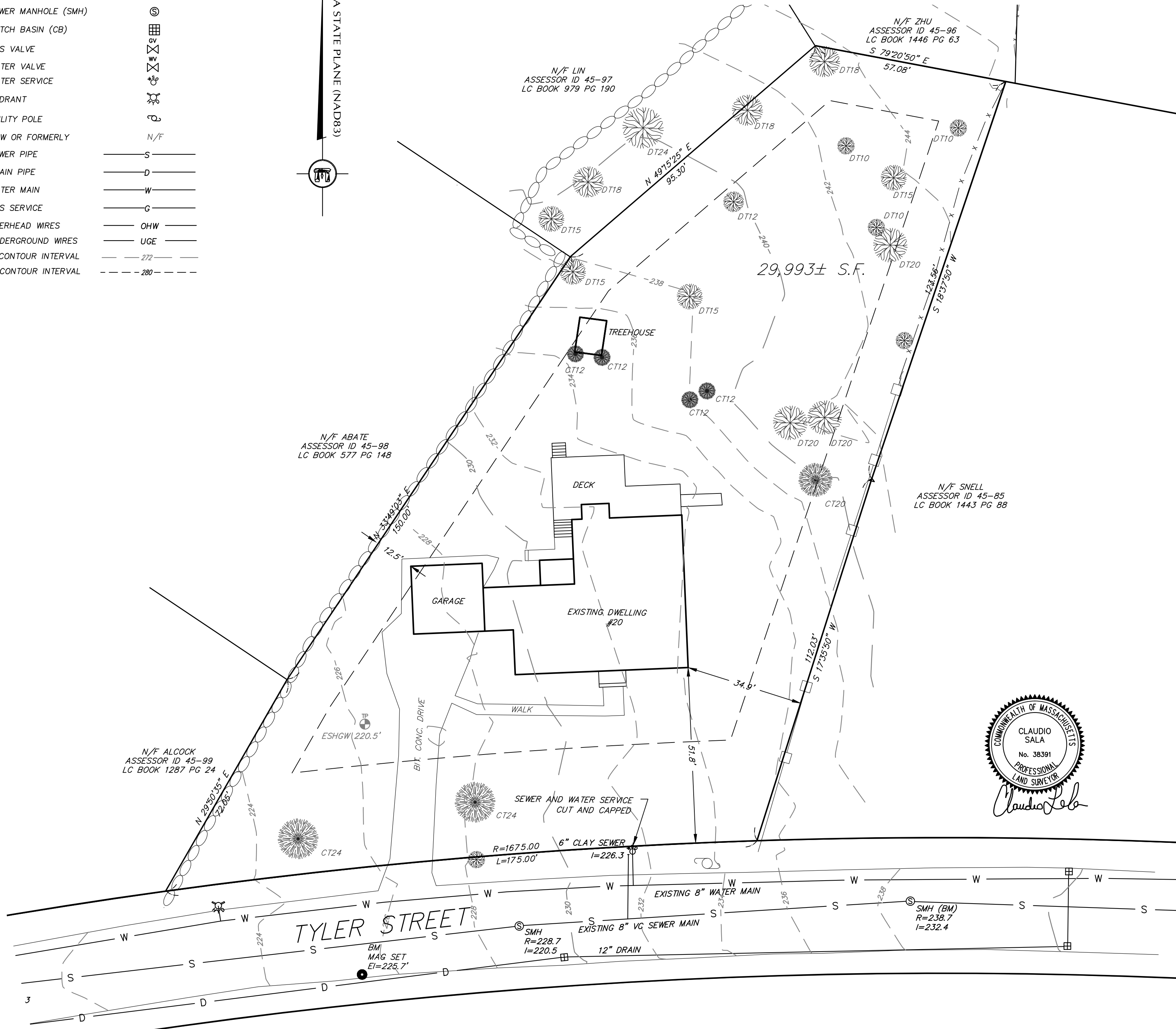
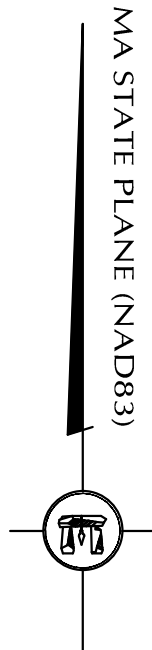

DeCelle-Burke-Sala

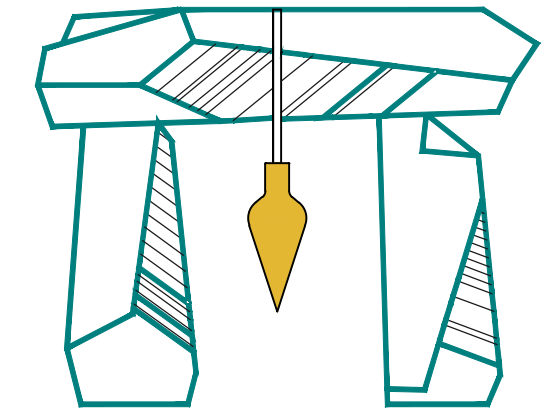

1266 Furnace Brook Parkway #401
 Quincy, MA 02169
 617-405-5100(O) 617-405-5101(F)
 www.decelle-burke-sala.com

GENERAL NOTES:

- LOCUS: ASSESSORS MAP 45 LOT 084
 RECORD OWNER: 20 TYLER, LLC
 MARK BARONS, MANAGER
 DEED REFERENCE: CERTIFICATE # 268837
 PLAN REFERENCE: LC PLANS 10065L&I
- THIS PLAN IS THE RESULT OF AN ON THE GROUND SURVEY PERFORMED BY THIS OFFICE IN AUGUST 2018.
- ELEVATIONS SHOWN HEREON ARE ON NAVD 88.
- EXISTING UTILITIES SHOWN ON THIS PLAN ARE COMPILED AND APPROXIMATE. PRIOR TO ANY CONSTRUCTION THE CONTRACTOR SHALL CONTACT DIG-SAFE AT 1-888-344-7233 FOR ACTUAL SITE MARKINGS. STATE LAWS REQUIRE A MINIMUM OF 72 HOURS NOTICE PRIOR TO ANY EXCAVATION.
- DIG-SAFE SHALL BE NOTIFIED PER THE STATE OF MASSACHUSETTS STATUTE CHAPTER 82, SECTION 409 AT TEL. 1-888-344-7233. THE ENGINEER DOES NOT GUARANTEE THEIR ACCURACY OR THAT ALL UTILITIES AND SUBSURFACE STRUCTURES ARE SHOWN. LOCATIONS AND ELEVATIONS OF UNDERGROUND UTILITIES WERE TAKEN FROM RECORD PLANS. THE CONTRACTOR SHALL VERIFY SIZE, LOCATION, AND INVERTS OF UTILITIES AND STRUCTURES AS REQUIRED PRIOR TO THE START OF CONSTRUCTION.
- THE LOCUS DOES NOT LIE WITHIN A FLOOD HAZARD ZONE AS INDICATED ON FIRM 25017C-0411E DATED JUNE 4, 2010.
- PARCEL IS ZONED RO.
 MIN. LOT AREA = 30,000 S.F.
 MIN. FRONTAGE = 150 FT.
 MIN. FRONT YARD = 30 FT.
 MIN. SIDE YARD = 15 FT.
 MIN. REAR YARD = 15 FT.

PROJECT TITLE & LOCATION:

PLAN OF LAND
 in
LEXINGTON, MA

20 TYLER STREET

PLAN TITLE:

EXISTING CONDITIONS

PREPARED FOR:

BARONS CUSTOM HOMES
 1 GARFIELD CIRCLE
 BURLINGTON, MA

DATE: SEPTEMBER 28, 2018

REVISED:

JOB NUMBER: 124.035 SHEET 1 OF 3

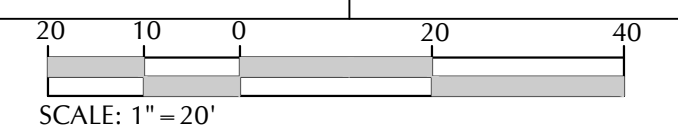

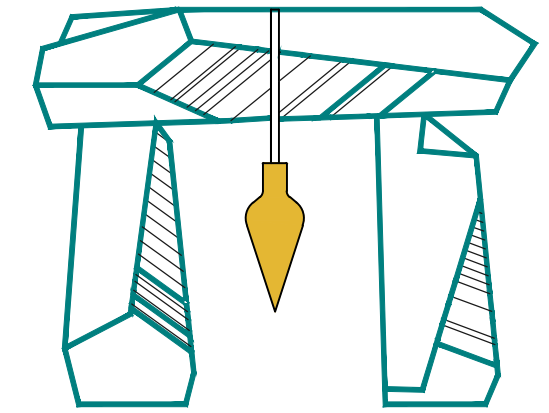

1266 Furnace Brook Parkway #401
Quincy, MA 02169
617-405-5100(O) 617-405-5101(F)
www.decelle-burke-sala.com

GENERAL NOTES:

- LOCUS: ASSESSORS MAP 45 LOT 084
RECORD OWNER: 20 TYLER, LLC
MARK BARONS, MANAGER
DEED REFERENCE: CERTIFICATE # 268837
PLAN REFERENCE: LC PLANS 10065L&I
 - THIS PLAN IS THE RESULT OF AN ON THE GROUND SURVEY PERFORMED BY THIS OFFICE IN AUGUST 2018.
 - ELEVATIONS SHOWN HEREON ARE ON NAVD 88.
 - EXISTING UTILITIES SHOWN ON THIS PLAN ARE COMPILED AND APPROXIMATE. PRIOR TO ANY CONSTRUCTION THE CONTRACTOR SHALL CONTACT DIG-SAFE AT 1-888-344-7233 FOR ACTUAL SITE MARKINGS. STATE LAWS REQUIRE A MINIMUM OF 72 HOURS NOTICE PRIOR TO ANY EXCAVATION.
 - DIG-SAFE SHALL BE NOTIFIED PER THE STATE OF MASSACHUSETTS STATUTE CHAPTER 82, SECTION 409 AT TEL. 1-888-344-7233. THE ENGINEER DOES NOT GUARANTEE THEIR ACCURACY OR THAT ALL UTILITIES AND SUBSURFACE STRUCTURES ARE SHOWN. LOCATIONS AND ELEVATIONS OF UNDERGROUND UTILITIES WERE TAKEN FROM RECORD PLANS. THE CONTRACTOR SHALL VERIFY SIZE, LOCATION, AND INVERTS OF UTILITIES AND STRUCTURES AS REQUIRED PRIOR TO THE START OF CONSTRUCTION.
 - THE LOCUS DOES NOT LIE WITHIN A FLOOD HAZARD ZONE AS INDICATED ON FIRM 25017C-0411E DATED JUNE 4, 2010.
 - ROOF DRAINS SHALL CONNECT TO THE PROPOSED CULTIEC RECHARGE SYSTEM. THE CULTIECS PROVIDE PROTECTION FOR THE SURROUNDING AREA FROM RELATED STORMWATER IMPACTS.
 - PARCEL IS ZONED R0.
- MIN. LOT AREA = 30,000 S.F.
MIN. FRONTAGE = 150 FT.
MIN. FRONT YARD = 30 FT.
MIN. SIDE YARD = 15 FT.
MIN. REAR YARD = 15 FT.

PROJECT TITLE & LOCATION:

PLAN OF LAND
in
LEXINGTON, MA

20 TYLER STREET

PLAN TITLE:

PROPOSED LAYOUT & UTILITIES PLAN

PREPARED FOR:

BARONS CUSTOM HOMES
1 GARFIELD CIRCLE
BURLINGTON, MA

DATE: SEPTEMBER 28, 2018

REVISED:

JOB NUMBER: 124.035 SHEET 2 OF 3

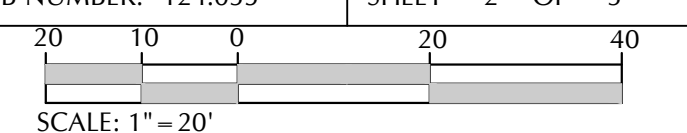

LEGEND:

EXISTING:		PROPOSED:
⊙ SMH	- LOCUS PROPERTY LINE	⊙ SMH
⊙ DMH	- SEWER MANHOLE (SMH)	⊙ DMH
⊠ CB	- DRAIN MANHOLE (DMH)	⊠ CB
⊗	- CATCH BASIN (CB)	⊗
⊗	- GAS VALVE	⊗
⊗	- WATER VALVE	⊗
⊗	- GAS SERVICE	⊗
⊗	- WATER SERVICE	⊗
⊗	- HYDRANT	⊗
⊗	- UTILITY POLE	⊗
N/F	- NOW OR FORMERLY	
D	- DRAIN PIPE	D
W	- WATER MAIN	W
G	- GAS SERVICE	G
OHW	- OVERHEAD WIRES	OHW
S	- SEWER MAIN	S
-280-	- GRADE	280
X15.6	- SPOT GRADE	15X6
□ □	- HAND HOLES FOR UTILITIES	□ □

ZONING SUMMARY:

CURRENT ZONING: RESIDENTIAL (RS)

	REQUIRED	PROVIDED
LOT AREA	15,500 S.F.	16,663 S.F.
FRONTAGE	150'	115'
SETBACKS		
FRONT	30'	33.2'
SIDE	15'	17.9'
REAR	15'	95.9'

BUILDING HEIGHT CALCULATIONS

AVG. NATURAL GRADE 233.6'
MAX. BLDG. ELEV. ALLOWED BY ZONING
(40'+233.6' = 273.6')
PROPOSED RIDGE HEIGHT ABOVE FND.=36.2'
PROPOSED RIDGE HEIGHT ELEV. =
(36.2'+235.5' = 271.7')
**MAX. RIDGE HEIGHT - 36.2' ABOVE TOP OF FND.
271.7'-233.6'=38.1' ABOVE ANG**
271.7' < 273.6' CHECK OK

BASEMENT ELEVATION =
TOF=235.5'-BF=227.9=7.6
AVERAGE NATURAL GRADE (ANG)=233.6'
FINISHED FF EI (FFF)= 236.8'
FFF-ANG = 3.2' (<6' OK!)

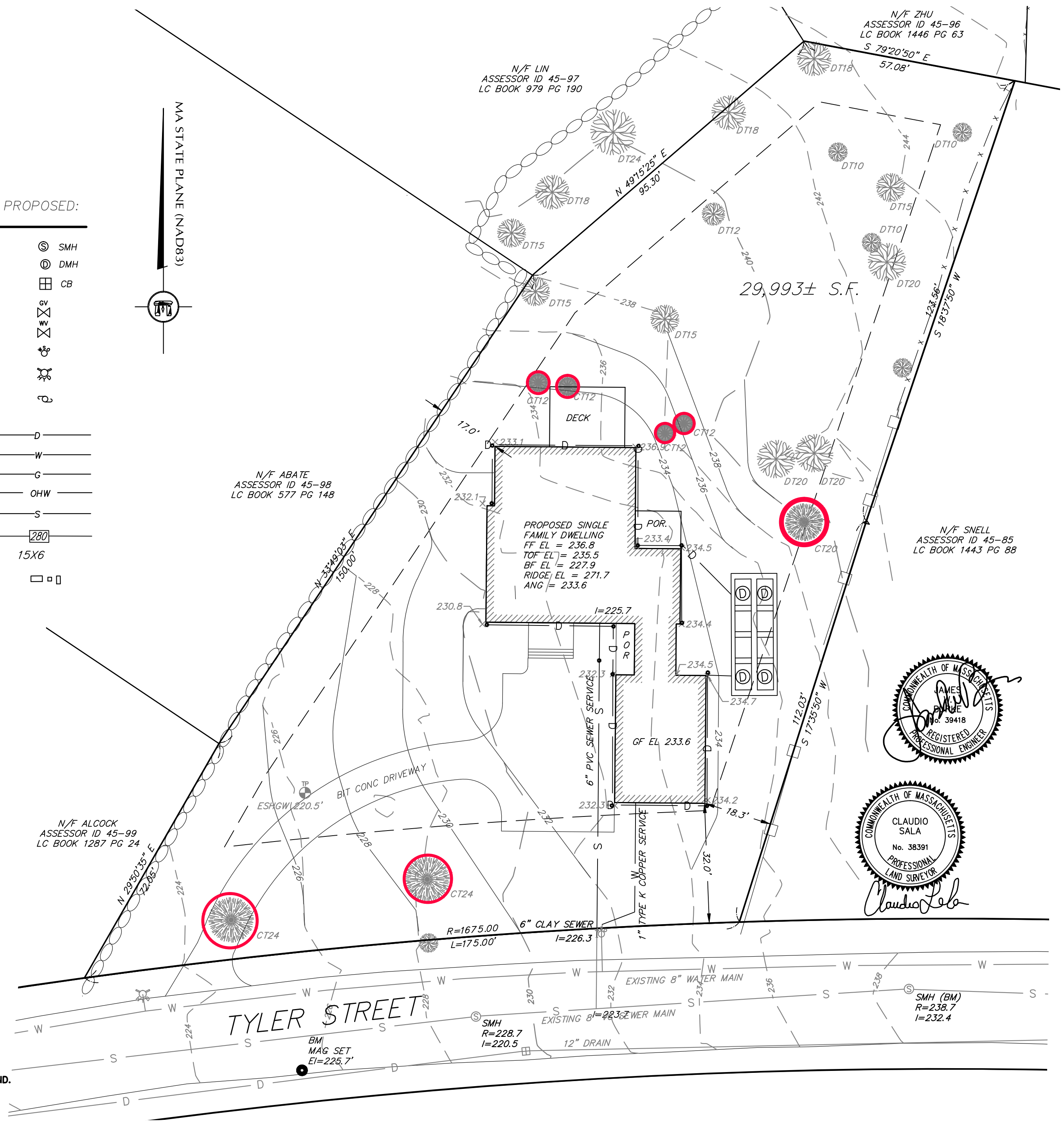

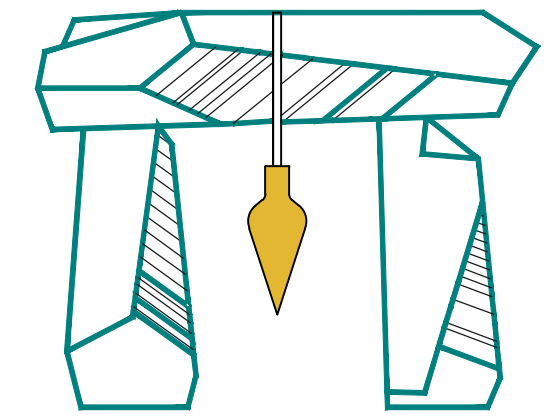

1266 Furnace Brook Parkway #401
Quincy, MA 02169
617-405-5100(O) 617-405-5101(F)
www.decelle-burke-sala.com

GENERAL NOTES:

- LOCUS: ASSESSORS MAP 45 LOT 084
RECORD OWNER: 20 TYLER, LLC
MARK BARONS, MANAGER
DEED REFERENCE: CERTIFICATE # 268837
PLAN REFERENCE: LC PLANS 10065L&I
- THIS PLAN IS THE RESULT OF AN ON THE GROUND SURVEY PERFORMED BY THIS OFFICE IN AUGUST 2018.
- ELEVATIONS SHOWN HERON ARE ON NAVD 88.
- EXISTING UTILITIES SHOWN ON THIS PLAN ARE COMPILED AND APPROXIMATE. PRIOR TO ANY CONSTRUCTION THE CONTRACTOR SHALL CONTACT DIG-SAFE AT 1-888-344-7233 FOR ACTUAL SITE MARKINGS. STATE LAWS REQUIRE A MINIMUM OF 72 HOURS NOTICE PRIOR TO ANY EXCAVATION.
DIG-SAFE SHALL BE NOTIFIED PER THE STATE OF MASSACHUSETTS STATUTE CHAPTER 82, SECTION 409 AT TEL. 1-888-344-7233. THE ENGINEER DOES NOT GUARANTEE THEIR ACCURACY OR THAT ALL UTILITIES AND SUBSURFACE STRUCTURES ARE SHOWN. LOCATIONS AND ELEVATIONS OF UNDERGROUND UTILITIES WERE TAKEN FROM RECORD PLANS. THE CONTRACTOR SHALL VERIFY SIZE, LOCATION, AND INVERTS OF UTILITIES AND STRUCTURES AS REQUIRED PRIOR TO THE START OF CONSTRUCTION.
- THE LOCUS DOES NOT LIE WITHIN A FLOOD HAZARD ZONE AS INDICATED ON FIRM 25017C-0411E DATED JUNE 4, 2010.
- ROOF DRAINS SHALL CONNECT TO THE PROPOSED CULTEC RECHARGE SYSTEM. THE CULTECs PROVIDE PROTECTION FOR THE SURROUNDING AREA FROM RELATED STORMWATER IMPACTS.
- PARCEL IS ZONED RO.
MIN. LOT AREA = 30,000 S.F.
MIN. FRONTAGE = 150 FT.
MIN. FRONT YARD = 30 FT.
MIN. SIDE YARD = 15 FT.
MIN. REAR YARD = 15 FT.

PROJECT TITLE & LOCATION:

PROPOSED SITE PLAN
in
LEXINGTON, MA

20 TYLER STREET

PLAN TITLE:

DETAIL SHEET

PREPARED FOR:

BARONS CUSTOM HOMES
1 GARFIELD CIRCLE
BURLINGTON, MA

DATE: SEPTEMBER 28, 2018

REVISED:

JOB NUMBER: 124.035

SHEET 3 OF 3

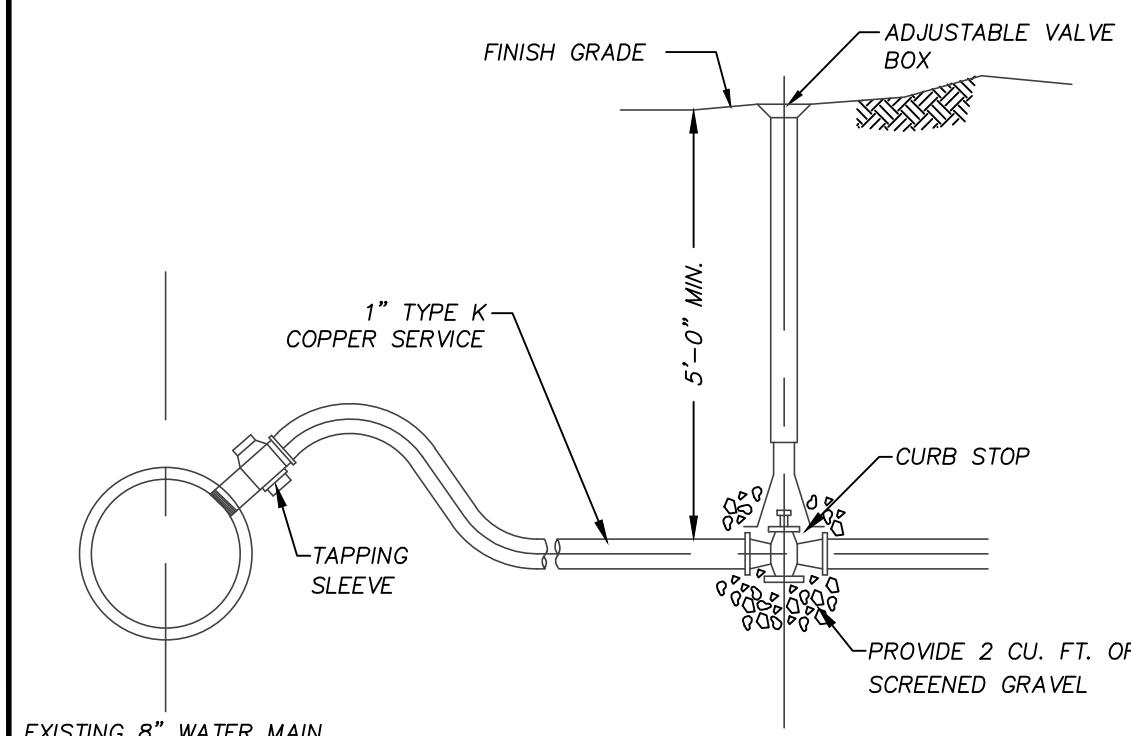
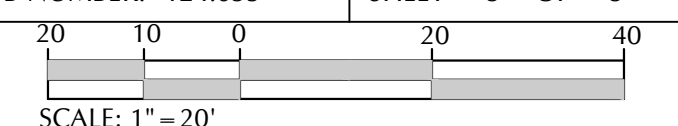

WATER SERVICE CONNECTION DETAIL
NOT TO SCALE

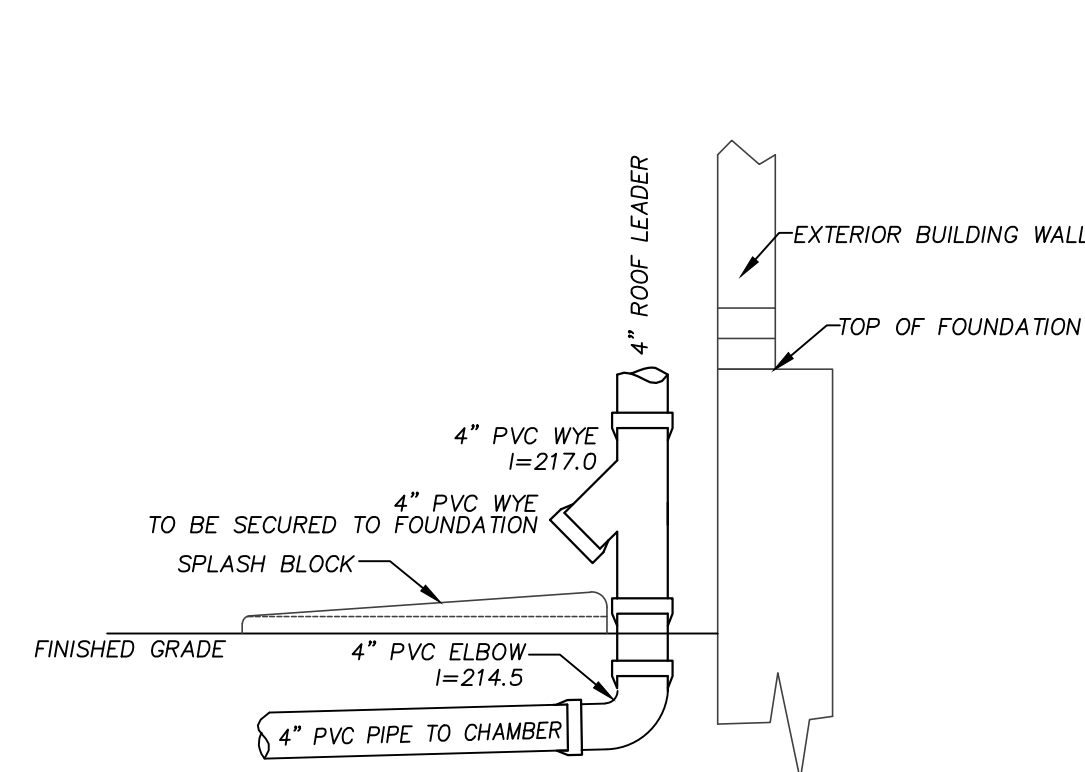

TYPICAL ROOF DRAIN W/ OVERFLOW
NOT TO SCALE

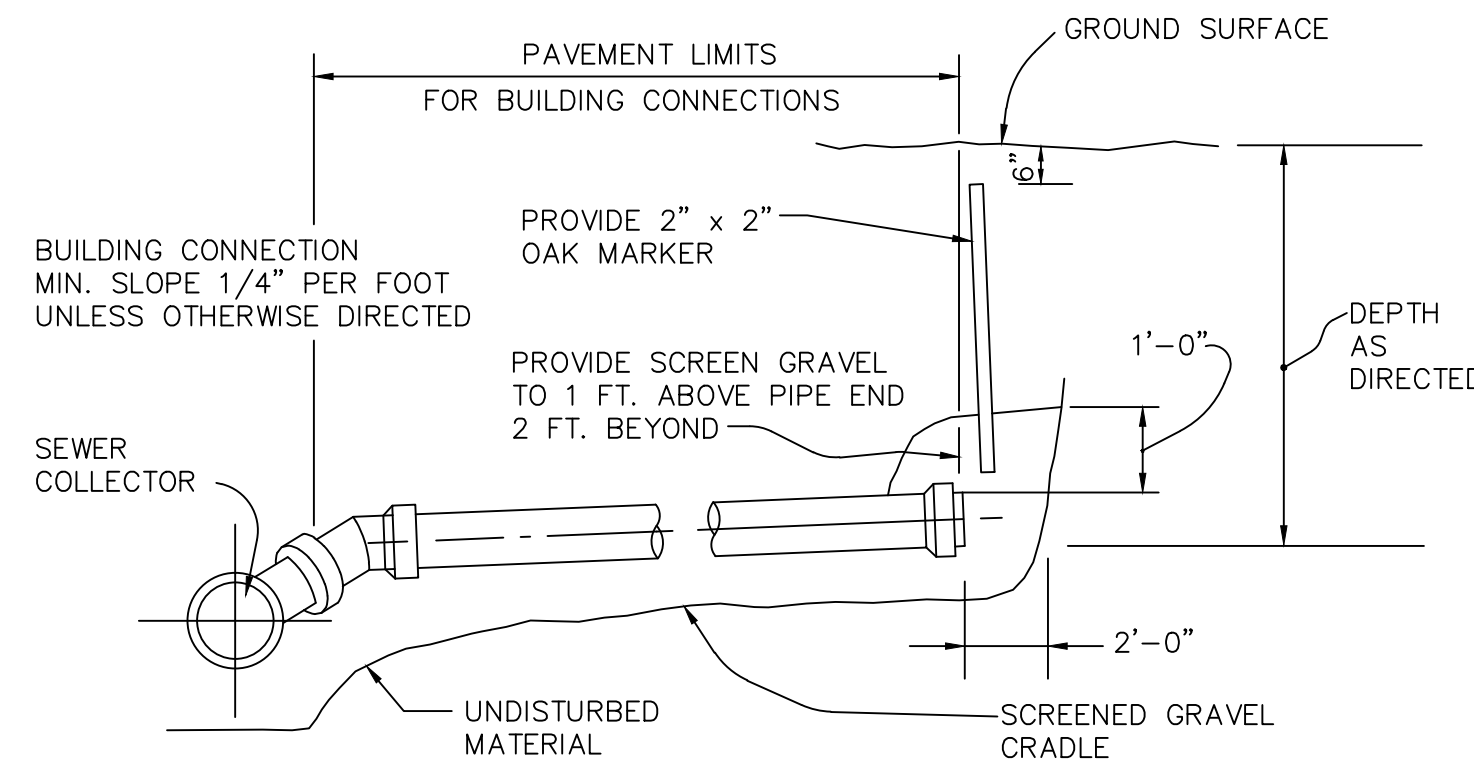
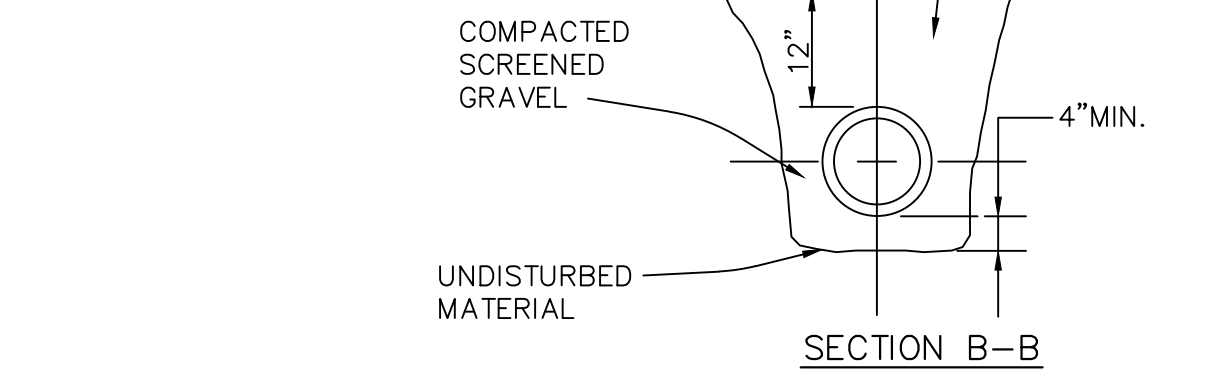
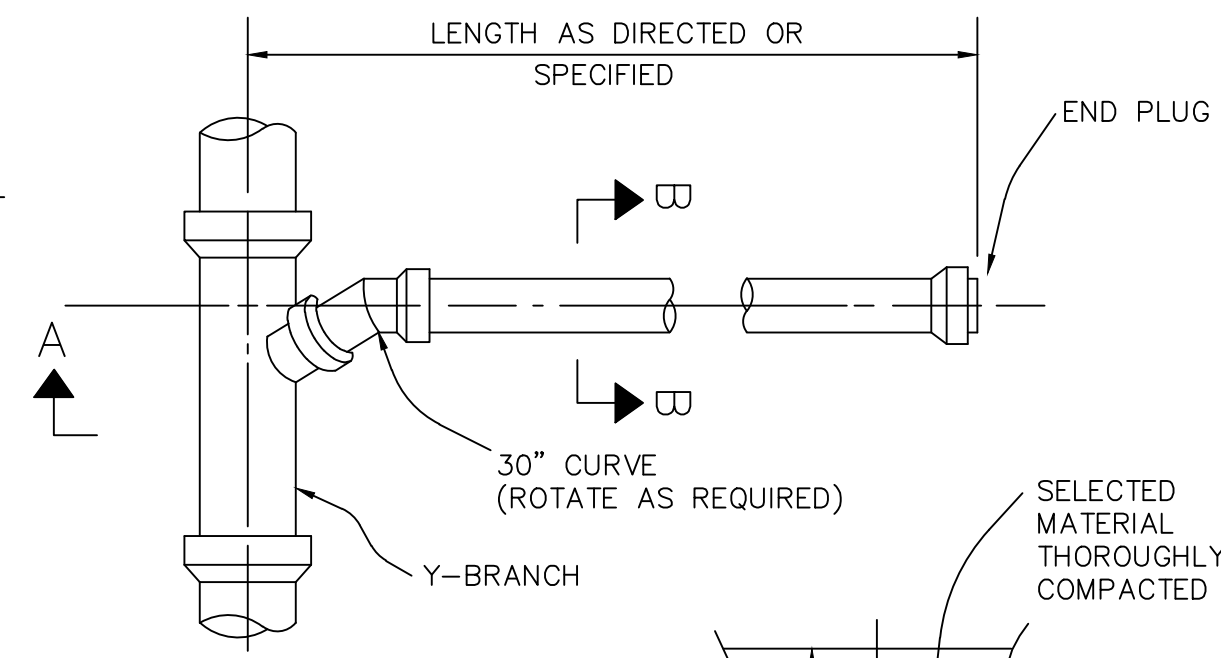

SECTION A-A
BUILDING SEWER CONNECTION
NOT TO SCALE

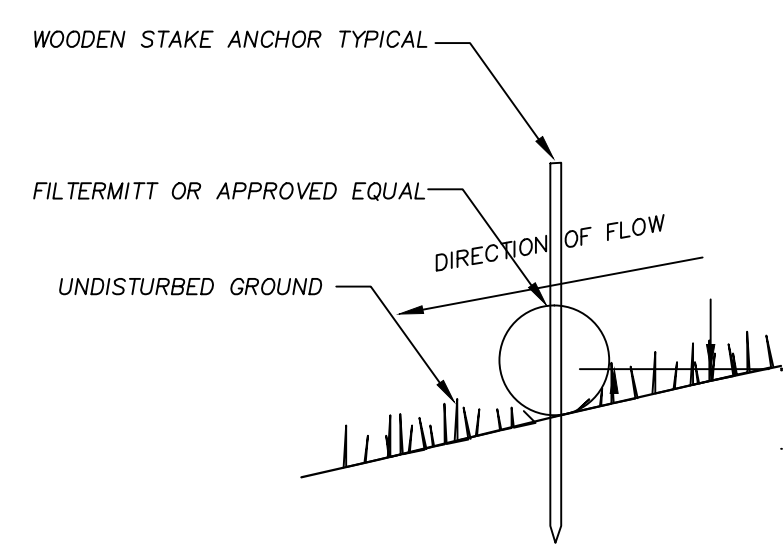
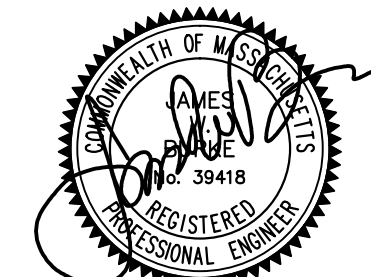

FILTERMITT OR EQUIVALENT
NOT TO SCALE

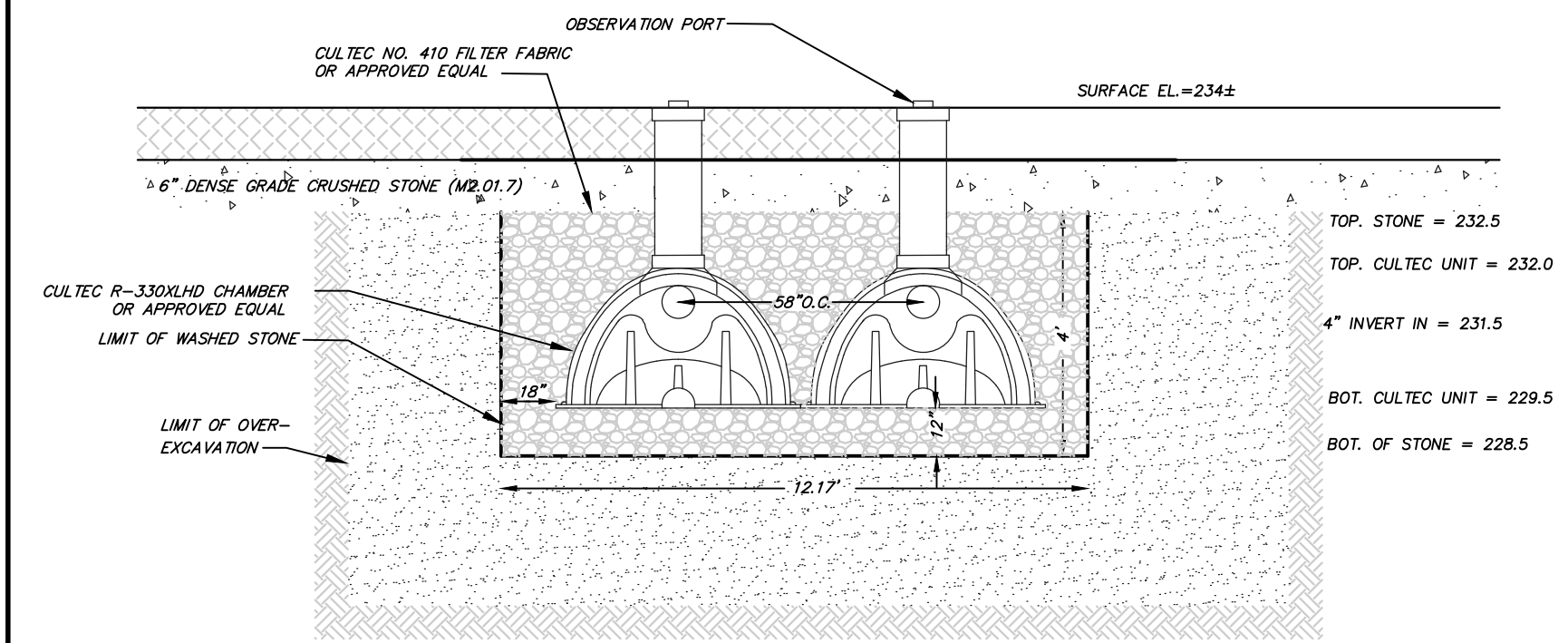

CULTEC CHAMBER TYPICAL SECTION
NOT TO SCALE

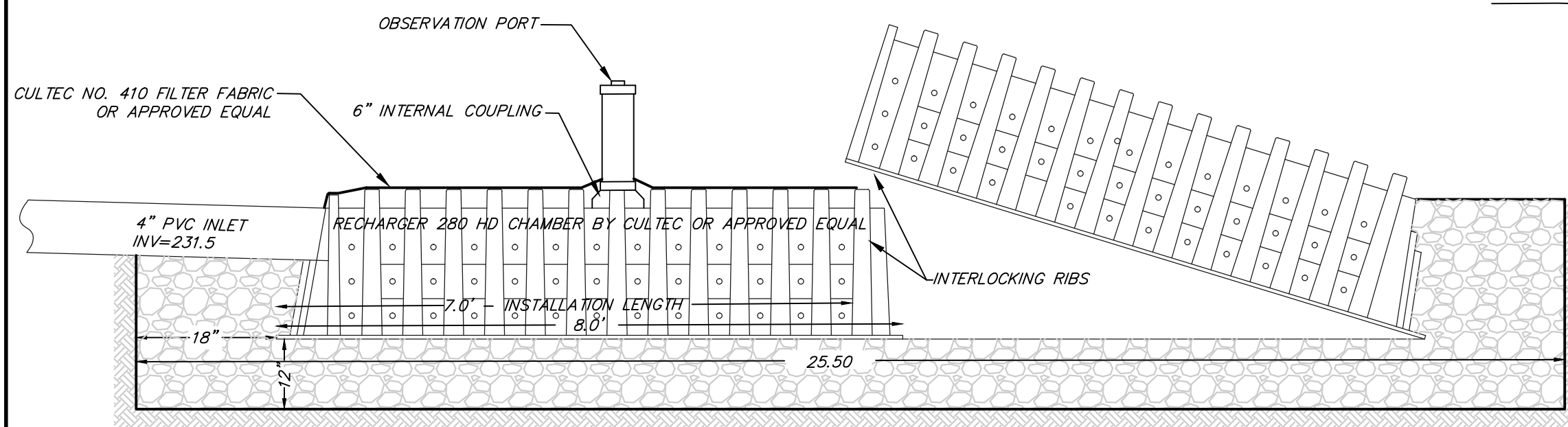

CULTEC CHAMBER TYPICAL PROFILE
NOT TO SCALE

OBSERVATION PORT INSTALLATION NOTES:

- CONTRACTOR TO CUT 6 inch diameter HOLE AT TOP OF CHAMBER IN THE CENTER OF THE UNIT.
- INSERT A 6 inch INTERNAL COUPLING INTO INSPECTION PORT OPENING.
- USE A 6 inch SCH.40 PVC PIPE TO BRING INSPECTION PORT TO WITHIN 6 inch OF FINISHED GRADE.
- INSTALL A 6 inch SCH.40 END CAP OR PLUG.
- BACKFILL IN ACCORDANCE WITH SPECIFICATIONS.

CULTEC CHAMBER INSTALLATION NOTES:

- CONTRACTOR TO INSTALL CULTEC CHAMBERS IN ACCORDANCE WITH MANUFACTURERS SPECIFICATIONS.
- CULTEC NO. 410 FILTER FABRIC OR APPROVED EQUAL TO BE PLACED OVER THE TOP OF THE DRAINAGE SYSTEM PRIOR TO BACKFILL.
- CONTRACTOR TO REMOVE ALL LOAM, SUBSOIL AND ALL DELETERIOUS MATERIAL FROM EXCAVATION PRIOR TO PLACEMENT OF THE STONE BED.